

CAMERAS AND MACHINE VISION TO SUPPORT ROUGH TERRAIN CONTAINER HANDLER OPERATIONS

Glenn Beach
Douglass Haanpaa
Gary Moody
Pritpaul Mahal
Steve Rowe
Gary Siebert
Jim Burkowski
Charles J. Cohen
Cybernet Systems Corporation
Ann Arbor, MI

ABSTRACT

The effective and safe use of Rough Terrain Cargo Handlers is severely hampered by the operator's view being obstructed. This results in the inability to see a) in front of the vehicle while driving, b) where to set a carried container, and c) where to maneuver the vehicles top handler in order to engage with cargo containers. We present an analysis of these difficulties along with specific solutions to address these challenges that go beyond the non-technical solution currently used, including the placement of sensors and the use of image analysis. These solutions address the use of perception to support autonomy, drive assist, active safety, and logistics.

INTRODUCTION

Rough Terrain Cargo Handlers (RTCH) are designed to lift, transport, and stack Intermodal Containers. Because of the size of the containers, the operator's view is often obstructed, leading to these particular difficulties:

- The visible path in front of the truck is blocked by the carried container, making driving more hazardous.
- The space in front of a carried container is obscured, making it difficult to judge where to set the container, especially in tightly packed unloading areas.
- The top surface of stacked containers cannot be seen by the operator, who must maneuver the top handler very precisely in order to engage the container's twist locks.

In this paper, we present an analysis of these difficulties along with specific solutions to address these challenges that go beyond the non-technical solution currently used (additional human spotters), including:

The use of strategically placed cameras, augmented with speed and steering data, to enhance the operator's situational awareness through:

- The use of cameras to provide the operator a view of the top of the container.
- The use of image analysis to provide the operator with control instructions to properly move the top handler in order to engage the container.
- The use of image analysis and a direct RTCH control interface to manipulate the top handler to achieve autonomous container engagement.

These solutions address the use of perception to support autonomy, drive assist, active safety, and logistics.

We will present the features and issues associated with the development of our applied solution, the RTCH Driver Assist Appliqué Kit for the Kalmar RT-240 Rough Terrain Container Handler. Next we will review the results from system demonstrations at the 2014 Limited Objective Experiment (LOE) at Ft. Eustis, VA and the 2015 Automation Demonstration at Aberdeen Proving Grounds (APG), MD. These Army experiments demonstrated increased operator efficiency along with reduction of

required ground crew. Finally, we conclude with a brief description of future work, which will discuss the use of camera data augmented with on-screen metrics and extending the interface and sensor algorithms to provide RTCH container placement support.

BACKGROUND

Intermodal Containers

Intermodal Containers are standardized containers that can be loaded on trucks, trains, ships. They come in two standard lengths: 20 feet and 40 feet long. Both include four attachment points. Our work focuses on the 20 foot container, but is applicable to both. The height of these containers varies, but the most common are 8.5’ and 9.5’. Our work focuses on both.

The attachment points are in the form of “twistlock” points (See Figure 1). Basically, a twistlock and corner casting form a standard rotating connector for securing connections between these Intermodal Containers (and also with the RTCH that can “grip” them). The twist lock will lock the container into place on a ship, a trailer, other containers, and also to the RTCH forklift. That is, the twist lock on the RTCH is inserted into the corner casting on the cargo container. There is not very much clearance, so the insertion has to be fairly precise. In order to grip a container, all four twist locks must be simultaneously aligned and then simultaneously inserted.



Figure 1: Left: twist lock. Right: corner casting.

Rough Terrain Container Handler (RTCH)

The Kalmar RT240 Rough Terrain Container Handler is a militarized model based off of the commercial design. As the name implies, it operates on rough terrain, such as beaches and other unimproved surfaces. The RTCH lifts, moves, stacks, and unstacks the standard 20’ and 40’ ISO container, able to stack them three high.

The single operator (driver) sits in an enclosed elevated cab in the center of the vehicle. The driver’s view is attenuated by forward and rear hydraulic fixtures, as well as the container if engaged. The 6’ diameter wheels also obscure objects that are on the ground close to the vehicle,

making it unsafe for pedestrians to approach while the RTCH is in operation.



Figure 2: The RTCH with an engaged container. Note the spotters at the back and front.

Because of these limitations, a ground crew is always present when the RTCH is in operation. Army doctrine demands a ground crew of be present during operation. The size of the crew varies from 1 to 3 persons based on congestion and visibility. For work in congested areas, such as container stacking zones, 3 persons are required: the control guide, the assistant, and the blind-spot guide (see Figures 2 and 3).

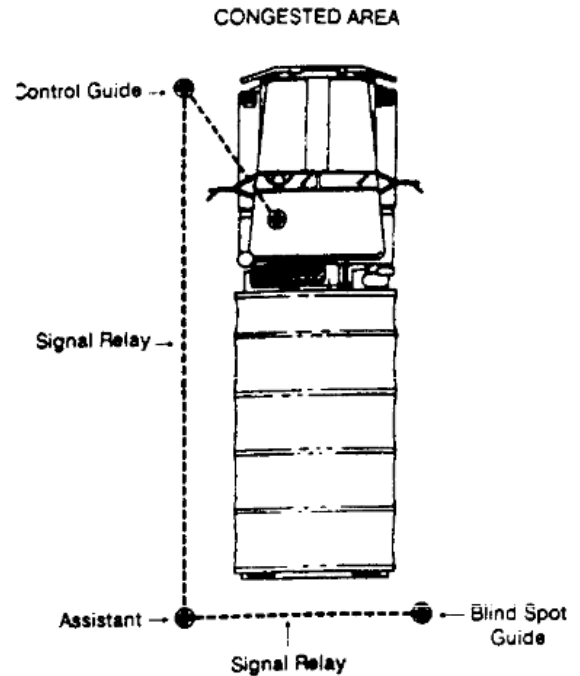

Figure 3: Positions of ground guides per Army doctrine [9]

The Top Handler is the end effector that interfaces with the Intermodal Containers through the use of twist locks. The Top Handler has 7 degrees of freedom: raise/lower boom, in/out, left/right, rotate clockwise/counterclockwise, rock left/right, swivel in/out, and in/out top handler extension (to

switch between 20' and 40' modes). These degrees of freedom are controlled through a single multi-function joystick.

Even with clear view, it is sometimes uncertain how to move the Top Handler. The operator needs to align the four twist locks, and at most only two can be seen because the farther two are completely obscured. The near two twist locks must be maneuvered into alignment accurately. Note that to make the operation of the RTCH somewhat easier, there is a special button sequence that allows the operator to raise/lower the Top Handler vertically without needed to directly manage the multiple degrees of freedom involved.

It is hard to tell if the twist lock is aligned with the corner fixture because the distance to the fixture is so far away that the operator's depth perception is extremely inaccurate. Distinguishing between moving the handler forward and back, as opposed to rotating the top handler, is difficult and a common operator error. Subtle motion of the top handler is difficult because the degrees of freedom overlap, and because of the sheer size of the top handler and the power provided by the hydraulic subsystem.

These difficulties are magnified when attempting to engage a container that is above operator's line of sight (such as, unstacking/picking a container on two of two already stacked containers).

CHALLENGES AND APPROACH

The goals of this effort were to use automation technology to improve the safety and effectiveness for the operator while reducing the number of ground crew required (i.e. non-operational personnel). In Figure 4, note that when the RTCH is carrying a container, the operator has an extremely limited field of view. This therefore requires the need for two or more ground crew to support operations (standard operating procedure requires a total of three), usually in a dangerous environment.

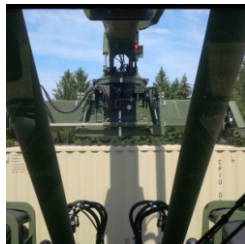

Figure 4: Obscured visible path.

This leads to three specific challenges we wish to address:

1. The visible path in front of the truck is blocked by the carried container, making driving more hazardous (see Figure 4). When carrying a container, the driver can't see the road. Lifting the container higher helps, but that raises the center-of-gravity which causes vehicle instability and the vehicle may tip over while on the road.
2. The space in front of a carried container is obscured, making it difficult to judge where to set the container, especially in tightly packed

unloading areas. When placing a container, the driver can't see how close the container is to colliding with other objects, including nearby containers it should be stacked with, other vehicles, and even the supporting ground crew.

3. The top surface of a container cannot be seen by the operator, who must maneuver the top handler very precisely in order to align the top handler's twist locks with container's corner fixtures (we call this "engaging the container").

Therefore, to address these challenges, we will analyse these difficulties along with specific solutions to address these challenges that go beyond the non-technical solution currently used (additional human spotters), including:

- The use of strategically placed cameras, augmented with speed and steering data, to enhance the operator's situational awareness.
- The use of cameras to provide the operator a view of the top of the container.
- The use of image analysis to provide the operator with control instructions to properly move the top handler in order to engage the container.
- The use of image analysis and a direct RTCH control interface to manipulate the top handler to achieve autonomous container engagement.

These solutions address the use of perception to support autonomy, drive assist, active safety, and logistics.

We will the present features and issues associated with the development of our applied solution, the RTCH Driver Assist Appliqué Kit for the Kalmar RT-240 Rough Terrain Container Handler. Next we will review the results from system demonstrations at the 2014 Limited Objective Experiment (LOE) at Ft. Eustis, VA and the 2015 Automation Demonstration at Aberdeen Proving Grounds (APG), MD. These Army experiments demonstrated increased operator efficiency along with reduction of required ground crew. Finally, we conclude with a brief description of future work, which will discuss the use of camera data augmented with on-screen metrics and extending the interface and sensor algorithms to provide RTCH container placement support.

INSTRUMENTATION

Sensor choice and placement is key to providing driver/operator assistance while ensuring safety. To address the goals and challenges from the previous section, we will detail the instrumentation implemented in various commercial forklifts.

Cameras

Generally, we use multiple Orlaco outdoor rugged cameras to support driver assist (see Figure 5). These are used to provide visual feedback to the operator from various viewpoints on the vehicle. Limitations include ensuring that the camera lenses remain clear, and that the image can be overwhelmed (saturated) if subjected to direct sunlight.



Figure 5: Orlaco outdoor cameras and mount.

3D Spinning LADAR

We utilize the Hokuyo UTM-30LX-EW LADAR, which uses laser illumination to detect the range to objects in the environment (see Figure 6). This LADAR can detect objects up to 30 meters away. Limitations include that the lens must remain clean, and that the LADAR can't see through heavy fog, snow, or rain.



Figure 6: Hokuyo UTM-30LX-EW LADAR.

IFM 3D Camera

We use 3D imaging flash LADAR cameras from IFM-efector (see Figure 7). These cameras have 300x300 pixel resolution, a 70 degree by 30 degree field of view. A range of up 4 meters, with a range accuracy of ± 1 cm. They are used to image the top surface of containers. Because these cameras are 3D we are able to get a textural information about the top of the container, specifically, they can indicate where the corner fixtures are. These images augment the visual data obtained by the corresponding Orlaco cameras.



Figure 7: IFM 3D Camera.

DELPHI RADAR

The XYZ Delphi automotive RADAR is used to detect obstacles behind the RTCH (see Figure 8). The 180 degree field of view allows the device to detect any potential obstacles when the vehicle is moving in reverse. Objects as small as a dog can be detected. The obstacle data augments the obstacle data from the 3D spinning LADAR.



Figure 8: DELPHI RADAR.

Touch Screen

A touch screen provides the operator with camera views, obstacle detection, alignment aids, and other information. The touch screen tablet is mounted on an adjustable rail that allows the operator to change the position of the screen inside the cab (see Figure 9). Operator can navigate screens to view desired information and/or system will switch to appropriate screen based on user actions.



Figure 9: Touch screen, mounted on lower right in the RTCH cab.

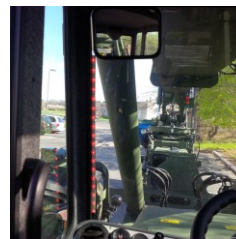

Figure 10: Red LED lights, illuminated, instructing the operator to stop all operations.

Window Lights

As a safety feature, red LED lights are mounted to the windshield and illuminate to provide warning to operator (see Figure 10). When the RED LED lights are on and audible alarm is on, the operator is being instructed to stop operations by the experiment supervisor.

All Stop System

As another safety system, an all stop system is integrated, which constantly monitors a wireless signal. If an experiment monitor wants operations to stop, they will send a wireless signal to the all stop system. When the vehicle receives the all stop signal, it will turn on the audible alarm and the windshield lights. These indicators will stay on until the monitor releases the stop signal. While the signals are active, the operator should cease operations.

SOLUTIONS

Limited Forward Visibility Challenge

The challenge here is that while the RTCH is carrying a container, the operator cannot see the road (see figure 3). While the container can be lifted out of the way, that is usually inconvenient and also potentially dangerous (leading to RTCH instability). Furthermore, the driver cannot see when the carried container is close to colliding with another one. These are challenges #1 and #2.

Our solution is to place two Orlaco cameras inside the top handler so that one of them will be facing forward no matter what the orientation of the carried container is. As shown in figure 11, the coverage of two cameras is delimited by the yellow and purple lines. In the figure the yellow Orlaco camera is facing forward. If the top handler is rotated 90 degrees clockwise, then the purple Orlaco camera is now the forward facing sensor and is then used for navigation.

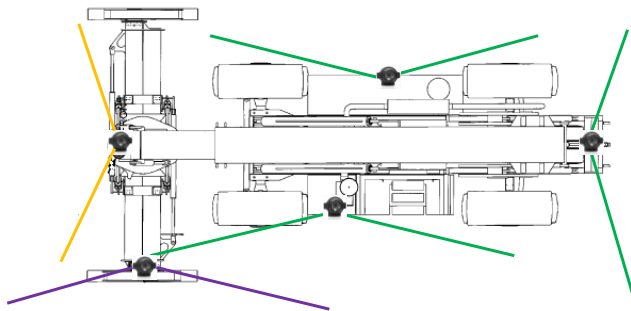

Figure 11: Camera coverage from yellow and purple cameras that provide forward looking views.

To address container placement, which includes knowledge the spacing between a carried container and another container, the same cameras are used. We use wide angle lenses which allow the sensor to observe the entire

length of a 20' container, albeit with minor distortion (as shown in figure 12). The bottom of this figure shows the in-cab operator assistance display, showing the clear view of the road ahead.



Figure 12: Forward view now visible with installed cameras.

Engaging the Container

Engaging the container refers to maneuvering the top handler in order to align the top handler's twist locks with container's corner fixtures. However, the top surface of a container usually cannot be seen by the operator because the top surface is above the view of the operator. Even when the operator can see the top surface, the distance between the operator and the nearest twist locks is such that the operator's depth perception is inadequate to the task of proper engagement. Therefore, the operator must rely on at least one spotter on the ground to succeed in this task. The spotter provides hand signals to the operator, who then moves the joystick accordingly.

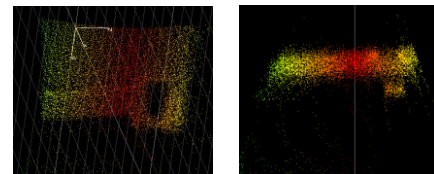

Figure 13: These images are of point clouds from IFM O3D Camera. Left: corner fixture of an ISO container as seen from above. Right: the same point cloud viewed from the side so as to show the depth of the corner fixture compared to the surface noise.

Our solution is the following. First, two IFM 3D cameras, located at opposite corners of the top handler, are used to locate the corner fixture in the top surface of the container. A 3D image (see Figure 13) of the top of the container is acquired and passed to the analysis software, which uses 3D template and probabilistic reasoning methods to find center

of corner fixture. If the system cannot detect the corner fixture after several frames, the operator is alert so that a gross movement of the top handler can be performed to recenter the top handler over the container. The system then attempts to acquire the corner fixtures again.

Next, the distance between the cameras and the corner fixtures is used to compute a reverse kinematic solution. As shown in Figure 14, multiple motions are frequently needed to align the top handler with the container, including rotations and translations. The camera vectors (distance from the camera to the container surface) are used to calculate these corrective actions.

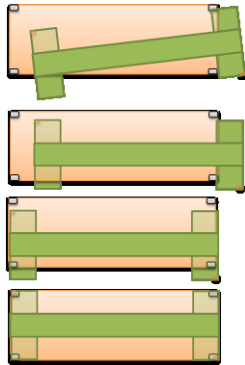

Figure 14: Sequence of rotations and translations to align the top handler with the container. Note that there is a height adjustment that is not shown in this figure.

Because a rotation changes two degrees of freedom simultaneously, we perform rotation operations first to allow for later operations to be simple translations. Also, to avoid collisions, we prefer to correct the tilt of the top handler (through the use of rotations) before lowering the top handler near to the top surface of the container.

As the top handler is lowered, the reverse kinematic estimate is updated and improved, so these operations are iterative. That is, we iteratively approach the correct solution, addition rotations and translations as required.

Experimental data shows that using these commands requires, on average, 15 seconds for a skilled operator to perform (30 seconds for a novice operator). When performing these actions autonomously (see “smart assist” below), this task takes, on average, 10 seconds to complete.

This reverse kinematic solution is then translated into specific operator joystick movements. The in-cab display shows the operator the same hand signal that a ground spotter would use (see Figure 15). The operator watches the screen in the same manner they would watch a spotter and moves the joystick accordingly. These hand signal displays are updated twice a second (based in the continually updated reverse kinematic solution). However, joystick movement will remain the same until the overall solution changes with a corresponding new joystick command. Hysteresis is

integrated into the commands to avoid rapid switching between different commands. Therefore, the commands, as seen by the operation, are smooth instructions as would be delivered by a ground spotter.

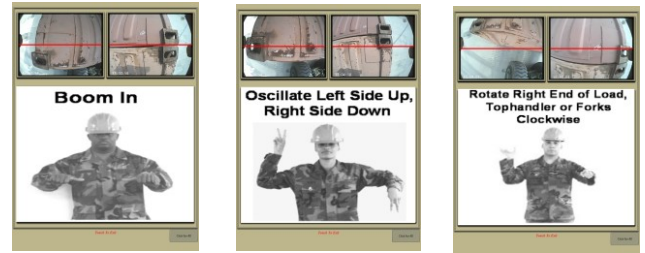

Figure 15: Three examples of hand signals shown to the operator by our system. The operator may use the camera images (at the top) to verify that the motions called for are correct.

We also developed software, which taps into the vehicle CAN bus, that automatically interprets the joystick instructions, automating the top handler movement. We call this solution: smart assist. In Smart Assist Mode, the operator doesn’t move the joystick – the hydraulics are controlled by the computer. Note that the operator still sees the requested operations as they are performed, including the associated camera views. As a safety feature, the operator can stop system at any time. Even with smart assist, the final lowering and engagement is still performed manually. This final engagement is a simple move down because the alignment has been completed.

CONCLUSIONS AND FURTHER WORK

The system is very robust in operation. Even potentially ambiguous situations, such as containers that are located next to each other (see Figure 16), are treated properly.

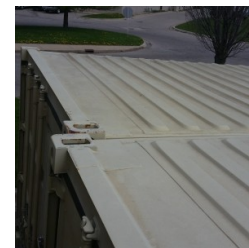

Figure 16: Containers stacked next to each other, yet the system identifies which corners are associated with the appropriate containers.

In the capability demonstration performed at Aberdeen Proving Ground in December, 2015, we demonstrated an improvement of operator efficiency in tasks including: positioning the RTCH, engaging a container, and obstacle avoidance. Importantly, these improvements were gained while also decreasing the number of spotters required.

Reduction in manpower is one of the stated goals of the Joint Forces, and this activity is important in achieving this goal.

We plan to further augment our system by adding additional sensor that will assist the operator in stacking a held container on top of another. This is difficult because the sensors used for aligning the top handler with the container are covered by the container once the top handler is engaged. Therefore, additional sensors are required to allow for the same field of view a spotter would have when guiding stacking operations.

ACKNOWLEDGEMENTS

The authors wish to thank Robert Forrester (US Army ARDEC – LRED), Paul Fournia (Materiel Systems Directorate, CASCOM), Brian Reed (Aberdeen Test Center), and the soldiers who performed the demonstration by manning the RTCH (SGT Webb, SGT Bradley, SPC Tiller, SPC Perez, and SSG Harris).

This work was funded under Army contract DOTC-13-01-INIT-155.

REFERENCES

- [1] Nguyen, Viet, et al. "A comparison of line extraction algorithms using 2D laser rangefinder for indoor mobile robotics." *Intelligent Robots and Systems, 2005.(IROS 2005)*. 2005 IEEE/RSJ International Conference on. IEEE, 2005.
- [2] Borges, Geovany Araujo, and Marie-José Aldon. "Line extraction in 2D range images for mobile robotics." *Journal of Intelligent & Robotic Systems* 40.3 (2004): 267-297.
- [3] Ringbeck, Thorsten. Hagebeuker, Bianca, "A 3D Time Of Flight Camera for Object Detection", *Optical 3-D Measurement Techniques 09*, December 2007.
- [4] Hussmann, S. Sandner, J. "Real-time Classification of Industrial Products Based on the Photonic-Mixer-Device Sensor Technology", *Sensors Application Symposium (SAS) 2014 IEEE*, Pages 267-271, Feb 2014.
- [5] Zhao, Meiyaun. Lienhart, Advanced Driver Assistant System, Intel Corporation, retrieved from: <http://www.intel.com/content/dam/www/public/us/en/documents/white-papers/advanced-driver-assistant-system-paper.pdf>, Nov 11, 2015
- [6] Delueg, Michael. "Exploiting Depth Sensing for 3D Interface and Complex Image Analysis", *Electronic Engineering Times Europe*, May 2013
- [7] 3D Cameras – System Description, ifm website, www.ifm.com/ifmuk/web/pinfo020_030_040.htm
- [8] Kalmar RTCH specifications. http://www.military-today.com/engineering/kalmar_rtch.htm
- [9] Manual for the Wheeled Vehicle Driver, FM 21-305/AFMAN 24-306. United States Army and United States Air Force. 1993.